



DEPARTMENT OF THE ARMY
ARMY AVIATION SUPPORT FACILITY
VIRGINIA ARMY NATIONAL GUARD
700 PORTUGEE ROAD
SANDSTON, VIRGINIA 23150-5050



JFHQ-VAAV-OT-AS

29 October 2008

MEMORANDUM FOR RECORD

SUBJECT: OH-58 Emergency Egress Procedures and Fuel Shut Off Location

1. The following information is provided to assist fire fighters and emergency medical personnel in locating emergency fuel shut off, flight crew egress locations, as well as information pertaining to fuel type, amount, and battery location.
2. The OH-58 is a light single engine observation helicopter designed to operate from prepared and unprepared landing areas. The fuel type for the OH-58 is JP-4, JP-8, or Jet A with a total capacity of 71.5 gallons.
3. Fuel shut off valve is located on the upper/overhead console above the pilot location (right front seat). The fuel handle is marked in red and is a fore and aft position lever. Pulling the fuel lever full aft will shut off the fuel supply to the aircraft engine.
4. The throttle for the OH-58 consist of a twist grip (motorcycle type) located on the collective pitch lever along with the idle detent switch above the twist grip. The collective is located on the left side of the pilot's seat. When the aircraft is in operation, the throttle is fully open in the counter clockwise direction. To shut off the throttle, the twist grip needs to be rotated clockwise while holding the idle detent switch down on.
5. The OH-58 battery location is in the left aft electronics compartment behind the rear passenger door. The battery is a 28 volt NICAD type with a twist to turn as a quick disconnect.
6. Aircraft consists of four doors for entry and exits. Doors are of bonded sheet metal with acrylic plastic windows. Each door may be jettisoned by means of an emergency handle.
7. Other emergency equipment upon the OH-58 is a first aid kit and one fire extinguisher. They are affixed to the right side of the co-pilot seat located between the pilot and co-pilot seats. The fire extinguisher is utilized only on personnel.

5 Encls

1. Fig 9-1 (Sheet 1 of 2)
2. Fig 9-1 (Sheet 2 of 2)
3. Fig 2-1 (Sheet 2 of 2)
4. Fig 2-1 (Sheet 2 of 2)
5. Fig 2-5 (Sheet 2 of 2)

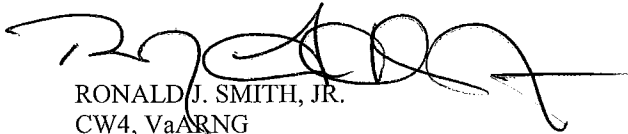
RONALD J. SMITH, JR.
CW4, VaARNG
AASF ASO/IP

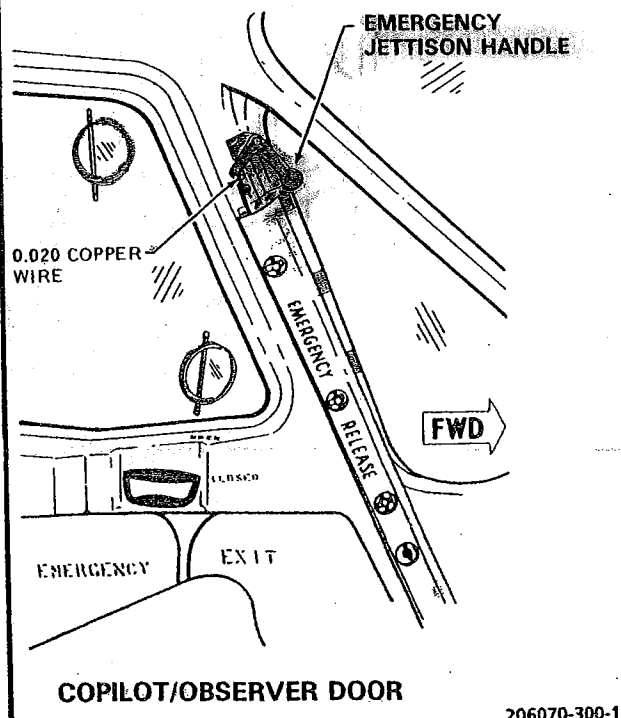
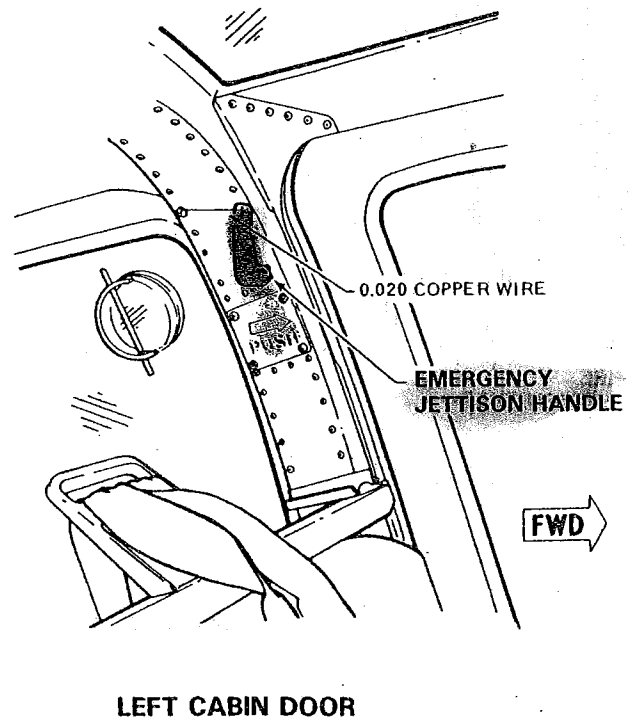
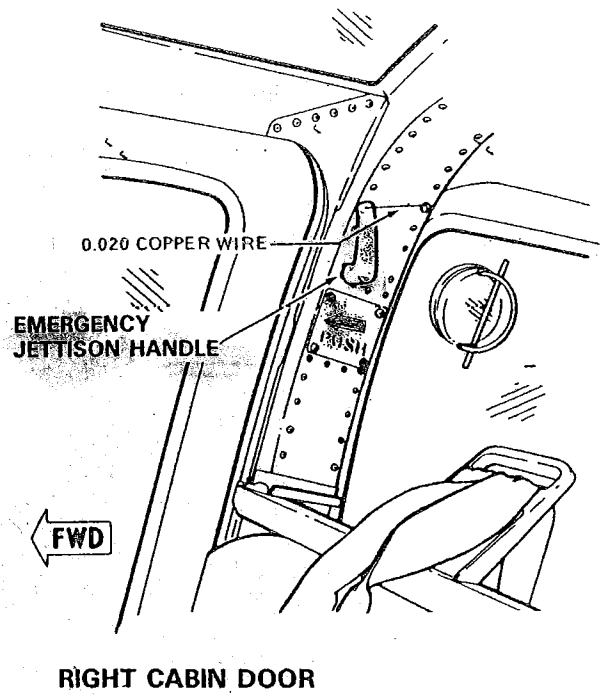
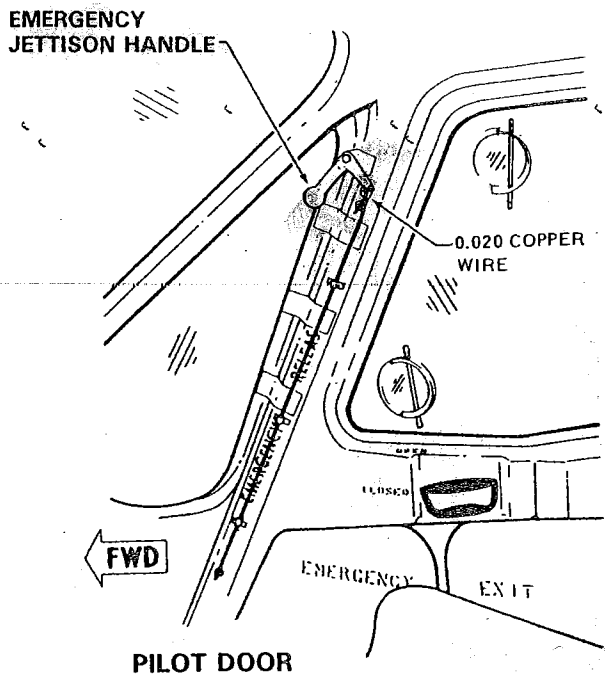
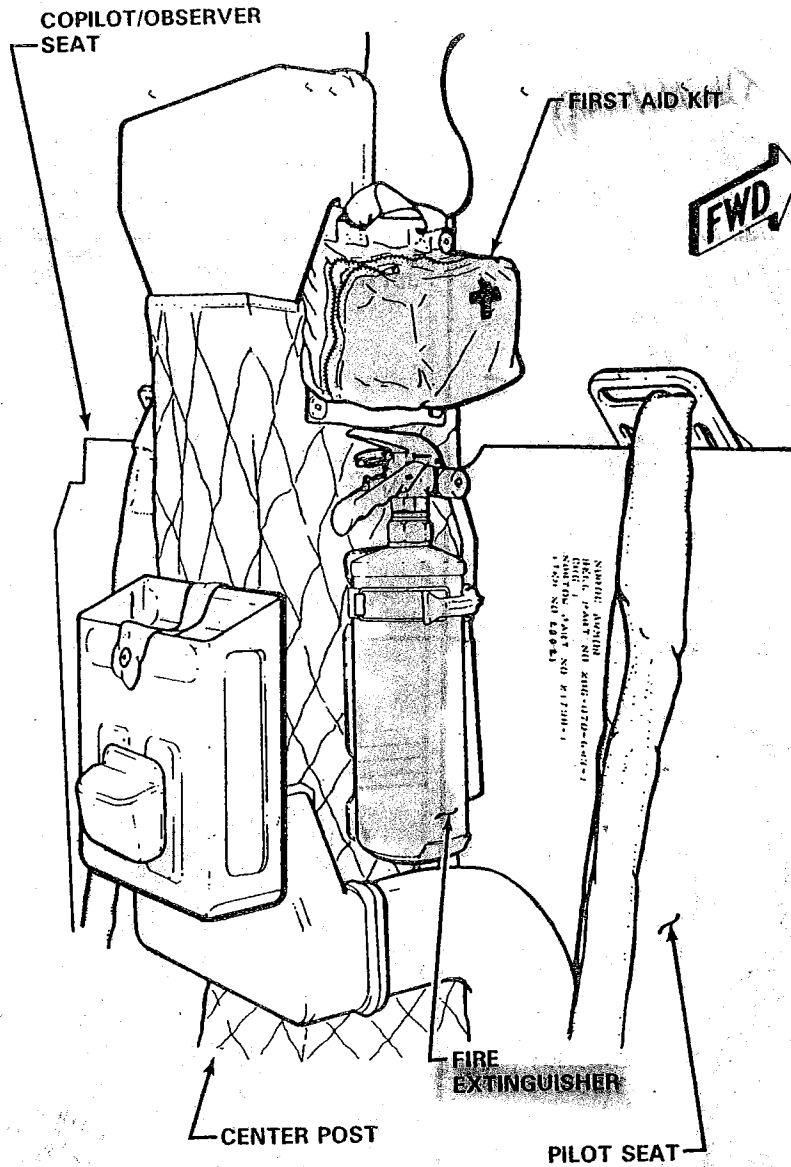
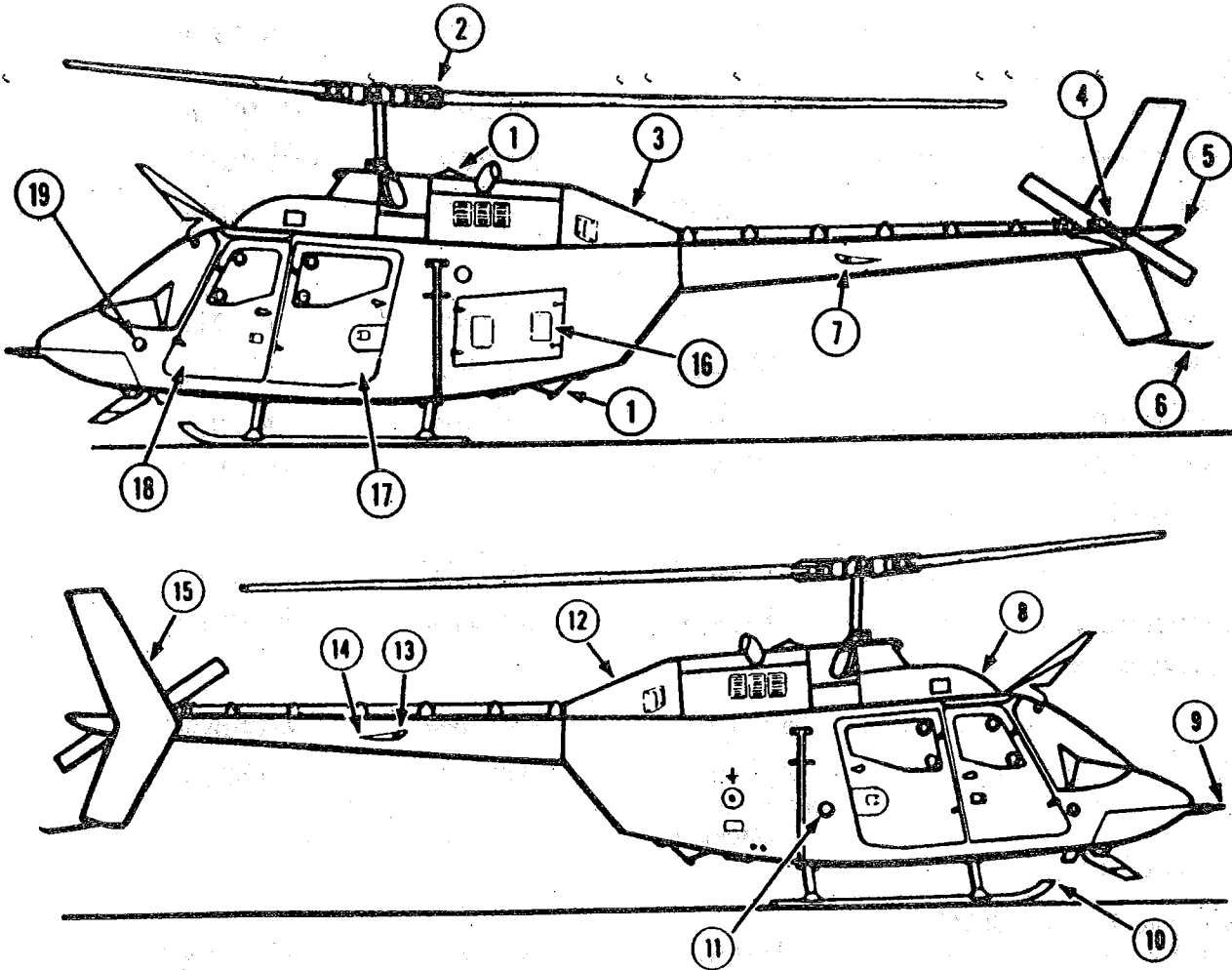

Figure 9-1. Emergency Exits and Equipment (Sheet 1 of 2)



206070-300-2

Figure 9-1. Emergency Exits and Equipment (Sheet 2 of 2)



- | | |
|--------------------------------------|---|
| 1. Anti-Collision Light | 14. Horizontal Stabilizer |
| 2. Main Rotor Hub and Blades | 15. Vertical Fin |
| 3. Engine Oil Tank Drain Access Door | 16. Battery and Avionics Compartment Door |
| 4. Tail Rotor Hub and Blade | 17. Passenger Door (Left) |
| 5. Position Light (White) | 18. Copilot Door |
| 6. Tail Skid | 19. Left Static Port |
| 7. Position Light (Red) | |
| 8. Forward Transmission Fairing | |
| 9. Pitot Tube | |
| 10. Skid Gear | |
| 11. Fuel Filler Cap | |
| 12. Aft Engine Cowling | |
| 13. Position Light (Green) | |

206900-507-1

Figure 2-1. General Arrangement (Sheet 1 of 2)

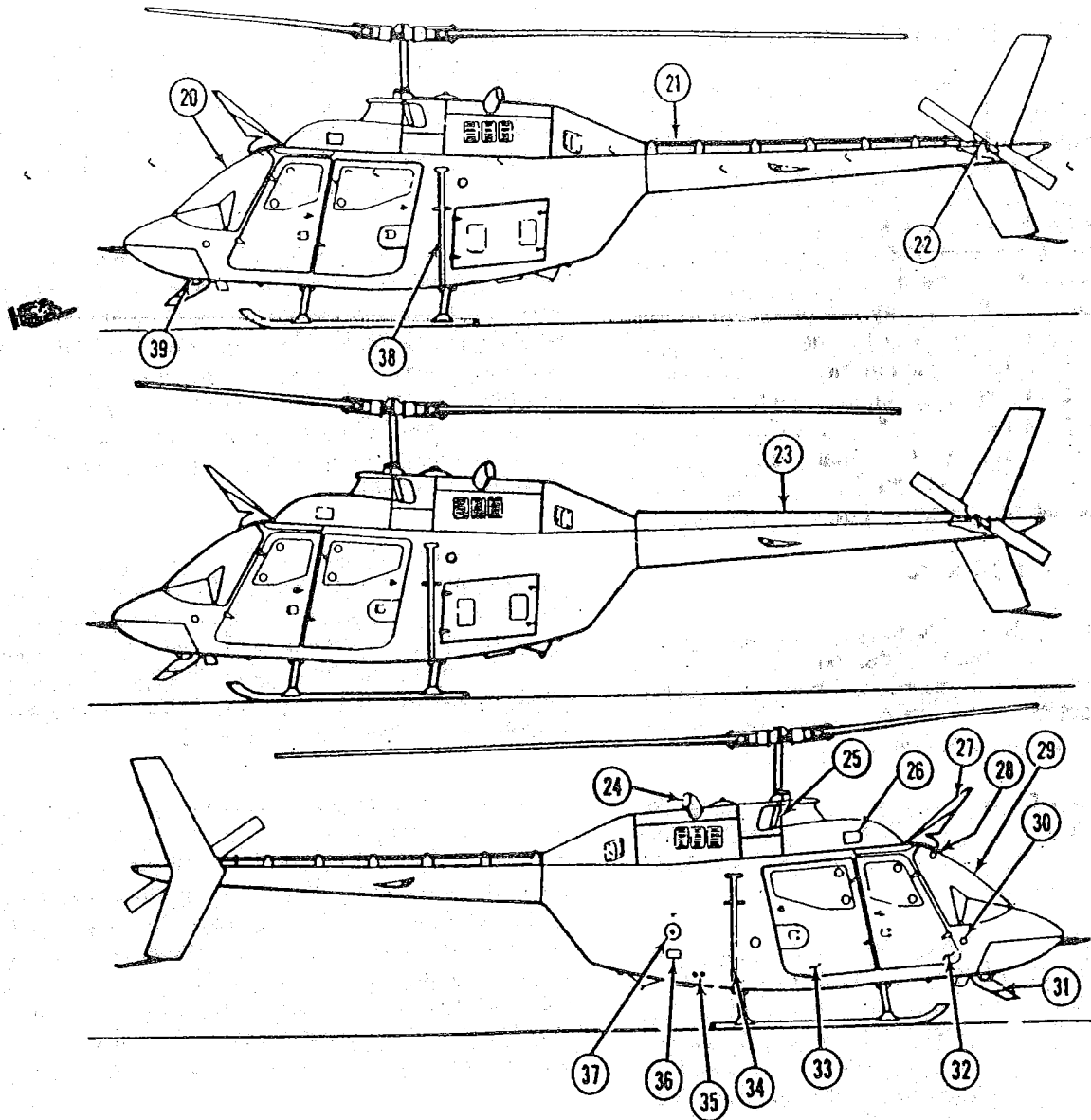

- | | |
|--|------------------------------------|
| 20. Windshield | 31. Lower Cutter Assembly |
| 21. Tail Rotor Driveshaft | 32. Pilot Door |
| 22. Tail Rotor Gearbox | 33. Passenger Door (Right) |
| 23. Tail Rotor Driveshaft and Cover (if installed) | 34. FM Homing Antenna (Right Side) |
| 24. Engine Exhaust | 35. Battery Vent |
| 25. Engine Air Inlet | 36. External Power Receptacle |
| 26. Forward Transmission Fairing Inspection Door | 37. Ground Receptacle |
| 27. Upper Cutter Assembly | 38. FM Homing Antenna (Left Side) |
| 28. Free Air Temperature (FAT) Gage | 39. Landing Light |
| 29. Windshield Deflector/Cutter Assembly | |
| 30. Right Static Port | |

206900-507-2

Figure 2-1. General Arrangement **A** (Sheet 2 of 2)

	HEIGHT	STANDARD SKID GEAR	HIGH SKID GEAR	FLOAT GEAR 
1.	Forward Tip of Main Rotor (Static Position to Ground with Droop)	9 ft. 6.0 in.	10 ft. 0.0 in.	9 ft. 7.9 in.
2.	Forward Tip of Main Rotor to Ground (Tie-Down)	12 ft. 0.0 in.	12 ft. 6.0 in.	12 ft. 1.9 in.
3.	Forward Tip of Main Rotor to Ground (Tie Down)	6 ft. 8.0 in.	7 ft. 2.0 in.	6 ft. 10.0 in.
4.	Ground to Top of Main Rotor Reservoirs	9 ft. 7.0 in.	10 ft. 9.0 in.	10 ft. 10.0 in.
5.	Bottom of Cabin	13.0 in.	27.0 in.	28.0 in.
6.	Top of Vertical Stabilizer	8 ft. 1.5 in.	10 ft. 1.5 in.	11 ft. 1.0 in.
7.	Tail Skid to Ground	1 ft. 4.4 in.	3 ft. 4.4 in.	4 ft. 4.0 in.
8.	Lower Cutter to Ground	12.0 in.	2 ft. 2.0 in.	2 ft. 3.0 in.
9.	Upper Cutter to Ground	7 ft. 9.5 in.	9 ft. 9.5 in.	9 ft. 10.5 in.
WIDTH				
10.	Skid Gear	6 ft. 5.4 in.	7 ft. 3.0 in.	11 ft. 6.1 in.
11.	Horizontal Stabilizer	6 ft. 5.2 in.	No Change	No Change
DIAMETERS				
12.	Main Rotor	35 ft. 4.0 in.	No Change	No Change
13.	Tail Rotor	5 ft. 2.0 in. or 5 ft. 5.0 in. (Improved)	No Change	No Change
LENGTH				
14.	Overall (Main Rotor Fore and Aft) to Aft End of Tail Skid	40 ft. 11.8 in.	No Change	No Change
15.	Nose of Cabin to Aft End of Tail Skid	32 ft. 2.0 in.	No Change	No Change
16.	Nose of Cabin to Center Line of 8 ft. 10.1 Main Rotor	8 ft. 10.1 in.	No Change	No Change
17.	Skid Gear	8 ft. 1.3 in.	10 ft. 4.2 in.	19 ft. 5.0 in.
18.	Nose of Cabin to Center Line of Forward Cross Tube	6 ft. 0.0 in.	5 ft. 9.4 in.	5 ft. 11.7 in.
19.	Nose of Cabin to Center Line of Aft Forward Cross Tube	10 ft. 9.0 in.	10 ft. 6.3 in.	10 ft. 8.7 in.
20.	Pitot Tube	6.8 in.	No Change	No Change

* Check antennas that may protrude lower

Figure 2-5. Principal Dimensions (Sheet 2 of 2)